



XGT60

Trailer-Mounted Expeditionary 60kw Generator System

We understand the importance of operational efficiency. We designed the UTS XGT60 Generator to operate longer, quieter, and more efficiently than the competition.



LONGER RUNTIME

24 HRS OF RUNTIME

QUIETER OPERATION

65DB @ 25FT

BETTER EFFICIENCY

4.4 GPH @ FULL LOAD

THE NEW STANDARD FOR EXPEDITIONARY OPERATIONS

The UTS XGT60 Generator delivers quiet, reliable power while offering dependable components, user-friendly controls, and abundant storage for both fuel and shelter systems.

FEATURES & BENEFITS

- **TRAILER-MOUNTED CONVENIENCE:** The XGT60 provides trailer-mounted delivery of 60kW of clean, quiet power.
- **STORAGE:** A tongue-mounted expedition rack, four (4) lockable compartments offer storage for power distribution accessories, and two (2) outboard cargo areas that are purpose-built for hauling UTS shelter systems.
- **SAFER RIDE:** A unique mounting approach provides a safer, smoother ride by lowering the center of gravity.
- **EASY MAINTENANCE:** Service panels provide “easy” access to engine fluids and components for simple, efficient maintenance.
- **SIMPLE INTERFACE:** Digital controller features system health monitoring while also offering advanced functionality.
- **COLD WEATHER CONFIDENCE:** Fuel-fired engine heaters come standard on every XGT60.
- **MULTI-FUEL OPERATION:** The XGT60 operates on an array of diesel and aviation fuels including DL1, DL2, JP5 and JP8.
- **COST CONSCIOUS:** The XGT60 does not require load banks to prevent wet stacking, saving on unnecessary costs.

©2023 UTS Systems, LLC
Current as of July 2022
Information subject to change without notice.

UTS Systems, LLC | 6051 North Lee Hwy, Fairfield, VA 24435
850.226.4301 | sales@uts-systems.com

uts-systems.com

DIMENSIONS



NSN ORDERING #

XXXXX

DT 8340-01-705-7116

OD 8340-01-705-7120

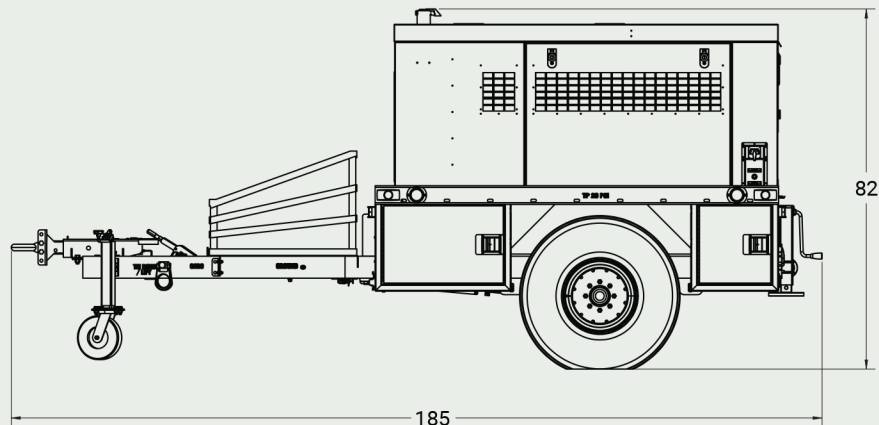
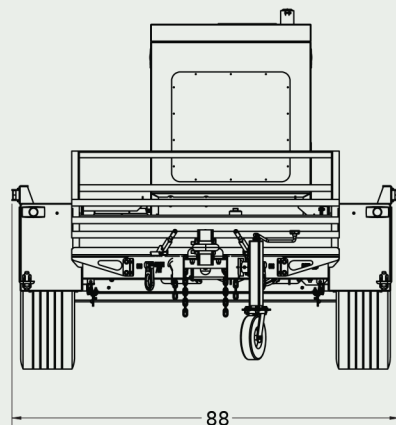

SPECIFICATIONS

RATED POWER	60 kW
OUTPUT	120 / 208 V, 3-Phase, 60 Hz
DRY WEIGHT	3,940 lbs
NOISE	65dB @ 25ft
OPERATING TEMP	-40 to 125°F
MOBILITY	HMMWV-towable, JLTV-towable

GENERATOR

FUEL	Requirements: Diesel, DL1, DL2, JP5, JP8 Capacity: 100 gal Consumption: 4.4 gph @ full load
EMISSIONS	EU Stage IIIA / U.S. EPA Tier 4i equivalent
ENGINE PRE-HEATER	Standard

OPTIONS

COLOR	Desert Tan, OD Green, or Coyote Brown
--------------	---------------------------------------