



XGT30

**Trailer-Mounted Expeditionary
30kw Generator System
with 5T or 8T ECU**

We understand the importance of operational efficiency. The XGT30 was designed to operate longer, quieter, than the competition.



LONGER RUNTIME

30 HRS OF RUNTIME

QUIETER OPERATION

65DB @ 25FT

BETTER EFFICIENCY

2.2 GPH @ FULL LOAD

THE NEW STANDARD FOR EXPEDITIONARY OPERATIONS

The UTS XGT30 Generator delivers quiet, reliable power and environmental control for expeditionary operations. The XGT30 combines dependable components, user-friendly controls, and abundant storage for both fuel and shelter systems.

FEATURES & BENEFITS

- **TRAILER-MOUNTED CONVENIENCE:** The XGT30 provides trailer-mounted delivery of 30kW of clean, quiet power; 5T or 8T of environmental cooling; and up to 18kW of heating.
- **STORAGE:** Four (4) lockable compartments offer storage for power distribution accessories, and two (2) outboard cargo areas are purpose-built for hauling UTS shelter systems.
- **SAFER RIDE:** A unique mounting approach provides a safer, smoother ride by lowering the center of gravity.
- **EASY MAINTENANCE:** Service panels provide “easy” access to engine fluids and components for simple, efficient maintenance.
- **SIMPLE INTERFACE:** Digital controller features system health monitoring while also offering advanced functionality.
- **COLD WEATHER CONFIDENCE:** Fuel-fired engine heaters come standard on every XGT30.
- **MULTI-FUEL OPERATION:** The XGT30 operates on an array of diesel and aviation fuels including DL1, DL2, JP5 and JP8.
- **COST CONSCIOUS:** The XGT30 does not require load banks to prevent wet stacking, saving on unnecessary costs.

©2023 UTS Systems, LLC
Current as of July 2022
Information subject to change without notice.

UTS Systems, LLC | 6051 North Lee Hwy, Fairfield, VA 24435
850.226.4301 | sales@uts-systems.com

uts-systems.com

DIMENSIONS



NSN ORDERING

5 TON
 DT 8340-01-705-7122
 OD 8340-01-705-7123

8 TON
 DT 8340-01-705-7116
 OD 8340-01-705-7120

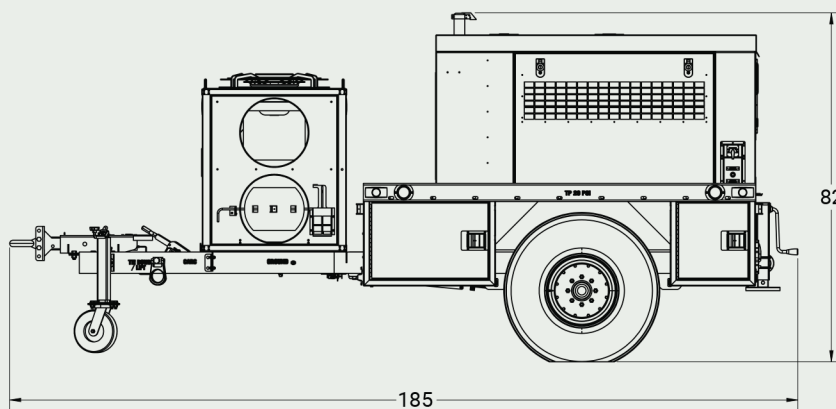
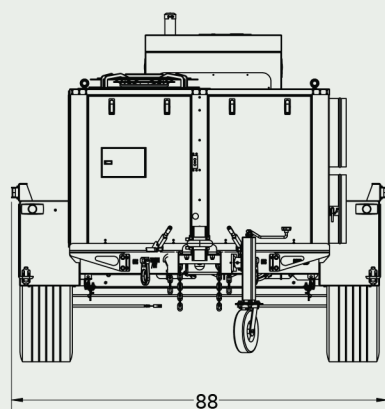

SPECIFICATIONS

RATED POWER	30 kW
OUTPUT	120 / 208 V, 3-Phase, 60 Hz
COOLING	60,000 BTU/h (5T) 96,000 BTU/h (8T)
HEATING	18kW
DRY WEIGHT	3,645 lb (5T) 3,810 lb (8T)
NOISE	65dB @ 25ft
OPERATING TEMP	-40 to 125°F
MOBILITY	HMMWV-towable, JLTV-towable

GENERATOR

FUEL	Requirements: Diesel, DL1, DL2, JP5, JP8 Capacity: 65 gal Consumption: 2.2 gph @ full load
EMISSIONS	EU Stage IIIA / U.S. EPA Tier 4i equivalent
ENGINE PRE-HEATER	Standard

ECU

SUPPLY AIRFLOW	1,800 CFM @ 1.75" ESP (5T) 3,000 CFM @ 1.00" ESP (8T)
FRESH AIRFLOW	0 - 240 CFM
SUPPLY / RETURN SIZE	16"

OPTIONS

COLOR	Desert Tan, OD Green, or Coyote Brown
--------------	---------------------------------------